



# OPERATION & INSTALLATION

## MANUAL

### Class B VHF Antenna Splitter



Version 1.1E

© True Heading 2008

The manual may not in any aspect be copied without the prior authorization from True Heading AB.

**TABLE OF CONTENTS**

TABLE OF CONTENTS..... 2

REVISION ..... 3

INTRODUCTION ..... 5

GLOSSARY..... 6

CONDITIONS ..... 8

WARRANTY ..... 9

    General..... 9

    Warranty conditions ..... 9

    Warranty procedures ..... 9

    Other issues ..... 9

SUPPORT ..... 10

SPECIFICATION ..... 11

INSTALLATION ..... 12

OPERATION ..... 16

TROUBLESHOOTING ..... 17

DECLARATION OF CONFORMITY ..... 18

FAQ ..... 20

NOTES ..... 21

DRAWINGS..... 22

### REVISION

Version	Date	Responsible	Approved	Changes
P1.0E	2008-07-29	Anders Bergström	Nils Willart	Preliminary release
1.0 E	2008-09-22	Anders Bergstrom	Nils Willart	1 <sup>st</sup> release
1.1 E	2008-10-02	Anders Bergstrom	Magnus Nyberg	2 <sup>nd</sup> release

Before operating the unit you should familiarise yourself with the complete user manual supplied with the product.



### **Electrical safety**

Make sure the power supply is switched off before you make any electrical connections to the unit.



### **Product installation**

This equipment must be installed in accordance with the instructions provided in this manual. Failure to do so could result in poor performance, personal injury and/or damage to your vessel and/or connected equipment.



### **General**

The compass safe distance of this unit is 0.5m or greater for 0.3° deviation.

In accordance with a policy of continual development and product improvement the CLASS B VHF ANTENNA SPLITTER hardware and software may be upgraded from time to time and future versions of the CLASS B VHF ANTENNA SPLITTER may therefore not correspond exactly with this manual.

When necessary upgrades to the product will be accompanied by updates or addenda to this manual. Information contained in this manual is liable to change without notice.

True Heading AB. disclaims any liability for consequences arising from omissions or inaccuracies in this manual and any other documentation provided with this product.

© 2008 True Heading AB.

### **INTRODUCTION**

Congratulations on the purchase of your AIS Transponder Antenna Splitter. It is recommended that your antenna splitter is installed by a professional installer.

The CLASS B VHF ANTENNA SPLITTER allows your existing VHF antenna to be used by both a VHF radiotelephone and an AIS Transponder.

The CLASS B VHF ANTENNA SPLITTER also includes an antenna connection for FM broadcast receivers providing a third use for your existing VHF antenna.

This manual describes the installation and operation of the CLASS B VHF ANTENNA SPLITTER.

### GLOSSARY

ACA	(AIS) Regional Assignment Channel Assignment Message
ACK	Acknowledgement
ACS	(AIS) Channel management information source messages
AFSK	Audio frequency-shift keying
ALR	(AIS) Alarm Message
A to N	Aid to Navigation
AIS	Automatic Identification System
ATC	Air Traffic Control
BIIT	Built In Integrity Testing
BNC	Bayonet fitting type RF connector
CSTDMA	Carrier Sense Time Division Multiple Access
COG	Course over Ground
CR	Carriage Return
CS	Carrier Sense
CSTDMA	Carrier Sense TDMA
DC	Direct Current
DGNSS	Differential Global Navigation Satellite System
DGPS	Differential Global Positioning System
DSC	Digital Selective calling
ETA	Estimated Time of Arrival
GALILEO	European equivalent to GPS
GLONASS	Global Navigation Satellite System
GNSS	Global Navigation Satellite System
GMSK	Gaussian Minimum Shift Keying
GPS	Global Positioning Satellite / System
HF	High Frequency
IMO	International Maritime Organization
IEC	International Electrotechnical Commission
LED	Light Emitting Diode
LF	Line Feed
LNA	Low-noise amplifier
MF	Medium Frequency
MKD	Minimum Keypad and Display
MMSI	Maritime Mobile Service Identity
MPE	Maximum Permissible Exposure
NM	Nautical Mile = 1852 m
NMEA	National Marine Electronics Association
PC	Personal Computer

## Class B VHF Antenna splitter Manual

---

PI	Presentation Interface
RF	Radio Frequency
RTCM	Radio Technical Commission for Maritime Services Commission
RX	Receive or Receiver
RFI	Radio frequency interference
SAR	Specific Absorption Rate
SELV	Separated Extra Low Voltage
SMA	Swedish Maritime Administration
SMS	Short Message System
SOG	Speed over Ground
SOLAS	Safety Of Life At Sea
SOTDMA	Self Organized Time Division Multiple Access.
SRM	Safety Related Message
SRT	Software Radio Technology
TDMA	Time-division Multiple Access
TNC	Threaded type BNC connector
TX	Transmit or transmitter
UTC	Universal Time Co-ordinated
VDM	(AIS) VHF Data Link Messages
VDO	(AIS) VHF data link own vessel messages
VHF	Very High Frequency
VTSS	Vessel Traffic Services (Like ATC but for ships)
VSWR	Voltage Standing Wave Ratio

### CONDITIONS

Before you start using the CLASS B VHF ANTENNA SPLITTER product from True Heading AB it is important that you read and fully understand the installation manual and its instructions. You should only proceed with the installation if you are confident that you will be able to do so.

True Heading AB cannot be held liable for any injury or damage caused by, during or because of the installation of CLASS B VHF ANTENNA SPLITTER. The CLASS B VHF ANTENNA SPLITTER is used at your own risk.

The CLASS B VHF ANTENNA SPLITTER installation should be inspected from time to time and checked on its operational quality frequently by the user. Remember that navigation and life at sea always requires proper seamanship and that the CLASS B VHF ANTENNA SPLITTER is not a replacement for such qualities.

**NOT ALL VESSELS CARRY AIS. IT IS THEREFORE IMPORTANT TO KEEP PROPER LOOKOUT AT ALL TIMES AND TO USE ALL AVAILABLE MEANS TO AVOID COLLISIONS AND ACCIDENTS.**

### WARRANTY

#### General

CLASS B VHF ANTENNA SPLITTER is developed and manufactured to meet high technical requirements and user demands. If installed correctly and with regular maintenance your CLASS B VHF ANTENNA SPLITTER should provide you with several years of operation and a very useful product. For further information provided in the manual and in this information sheet please consult the place where you purchased the CLASS B VHF ANTENNA SPLITTER or direct to our support.

#### Warranty conditions

- The warranty belongs to the person that purchased the product and cannot be handed over to a third party or person.
- The warranty is not valid if serial number is missing, seals broken or if the CLASS B VHF ANTENNA SPLITTER has been incorrectly installed. Neither is the warranty valid if instructions for connection have not been followed, faults caused by wrong usage, own made modifications or service made from non authorized service stations.
- True Heading AB acknowledges that CLASS B VHF ANTENNA SPLITTER at delivery has been controlled and found operational.
- True Heading AB agrees to repair or replace any faulty unit without any cost according to the conditions set forth during a period of two (2) years from day of purchase.
- The warranty includes replacement or repair of faulty unit due to error in components or errors in relation to the production of the product.
- The warranty covers costs for spares, labor, and return shipment. It does not include shipment from to the repair facility.
- True Heading AB will never be liable under the warranty conditions for incorrect use, misuse, and incidental, indirect or consequential damages of the CLASS B VHF ANTENNA SPLITTER.
- Proof of purchase is required for any warranty claim of the CLASS B VHF ANTENNA SPLITTER.

#### Warranty procedures

True Heading AB repairs and replaces faulty parts or units. The customer is responsible for transport of the defect part or unit to True Heading or its retailer.

Warranty claims shall be made to the place where CLASS B VHF ANTENNA SPLITTER was purchased or direct to True Heading AB through mail, fax or e-mail to our support department.

#### Other issues

Proper seamanship and common sense is applicable when using CLASS B VHF ANTENNA SPLITTER and the products shall only be seen as a navaid. True Heading AB keeps the right to change the specification of the product without prior notice.

**IF YOU ARE NOT ABLE TO ACCEPT THE TERMS ABOVE, PLEASE RETURN THE CLASS B VHF ANTENNA SPLITTER TO YOUR RETAILER FOR FULL CREDIT BEFORE OPENED AND USED.**

### SUPPORT

If you need support, please contact the closest reseller or the location where you acquired the product.

The manufacturer can also give support direct:

Email: [support@trueheading.se](mailto:support@trueheading.se) or Fax: +46 8 54593900.

Please register your purchase of CLASS B VHF ANTENNA SPLITTER with True Heading AB by sending an e-mail to [register@trueheading.se](mailto:register@trueheading.se) stating the serial number, date of purchase, your name, address and your dealer's name.



### SPECIFICATION

#### General

Size (H x W x D)	120 x 120 x 60mm
Mounting area (H x W)	145 x 120mm
Weight	260g
Power	12VDC or 24DC supply
Operating current (receive)	120mA typical at 12VDC
Operating current (VHF transmit)	
Operating current (AIS transmit)	

#### Environmental

Operating temperature	-15°C to +55°C
Operating humidity	Up to 93%
Storage temperature	-20°C to +70°C

#### RF performance

VHF & AIS Frequency range	156.025MHz to 162.025MHz
Insertion loss, AIS Receive path	< 4dB
Insertion loss, VHF Receive path	< 4dB
Insertion loss, AIS Transmit path	< 1dB
Insertion loss, VHF Transmit path	< 1dB
Max input power, AIS port	12.5W
Max input power, VHF port	25W
Min input power, VHF port	100mW
AIS port impedance	50 Ω
VHF port impedance	50 Ω
Antenna port impedance	50 Ω
FM port impedance	75 Ω
Switching time, Receive to AIS Transmit	<10uS
Switching time, Receive to VHF Transmit	<10uS

#### Connectors

Power	Flying lead
Antenna	SO-239 (UHF) connector
VHF Radiotelephone	SO-239 (UHF) connector
AIS Transponder	BNC
FM broadcast receiver	BNC

### INSTALLATION

#### 2.1 Before you start

The following items are supplied in the CLASS B VHF ANTENNA SPLITTER packaging:

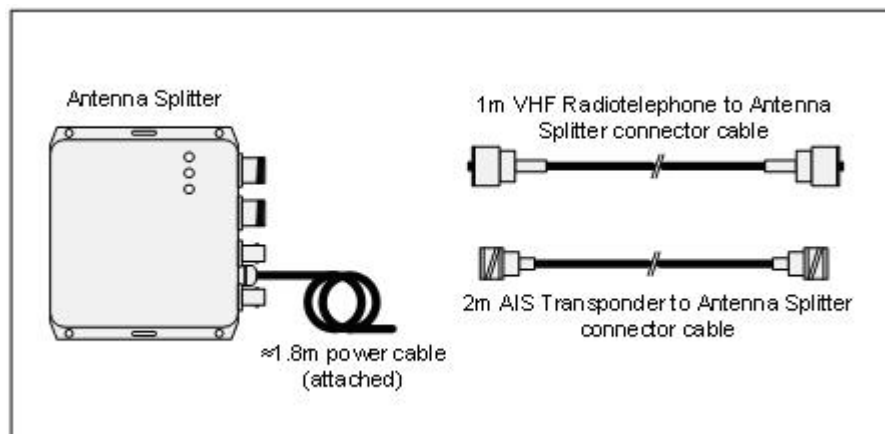

You will need the following items and tools to complete the installation:

- Class B AIS Transponder.
- Pre-installed VHF Antenna and cable.
- Access to 12V DC or 24V DC power supply where the unit is to be installed, via a 1A rated fuse or circuit breaker.
- Connector block or junction box for power connections.
- Four M4 (no. 6) screws or other fixings appropriate to the mounting location.

## 2.2 Installing the unit

Before starting installation select a suitable location for the antenna splitter. The unit is intended for installation below deck in a dry location. When locating the unit you should consider:

- Routing of power and antenna cables to the unit.
- Provision of sufficient space behind the unit for cable connections.
- Maintaining the compass safe distance of 0.5m.
- Visibility of the front panel indicators.

### Installation diagram

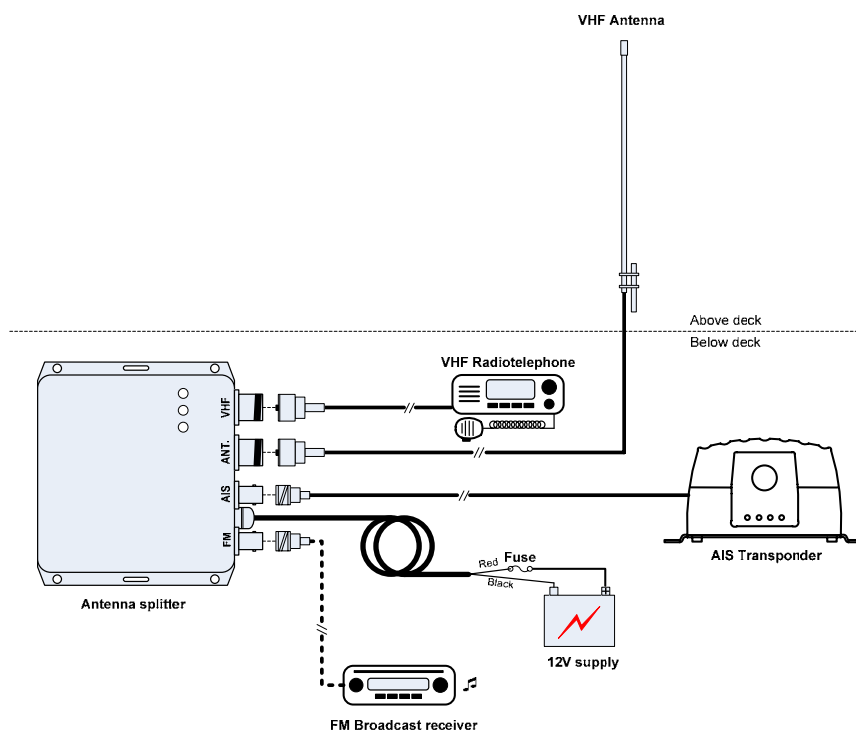

## Class B VHF Antenna splitter Manual

---

### Installation step 1

- Secure the antenna splitter to a flat surface in the selected location. Use four 5mm wood screws or other fixings suited to the material the unit is being fixed to.
- The unit may be installed in any orientation.
- Fixing point dimensions are shown below.



*(Not to scale)*

♪ = Connection for FM radio

**PWR** = Connect 12-24 V DC

**AIS** = Connect AIS-CTRX unit

**Y** = Connect antenna

**VHF** = Connect VHF radio

### Installation step 2

Make the electrical connections to the antenna splitter as follows:

- Connect the VHF antenna to the connector labelled 'Antenna'.
- Connect the antenna output of your VHF Radiotelephone to the connector labelled 'VHF'.
- Connect the antenna output of your AIS Transponder to the connector labelled 'AIS'.
- Optionally connect the antenna input of a FM Broadcast receiver to the connector labelled 'FM'.
- Connect 12VDC or 24VDC power supply to the power cable.
  - The red wire should be connected to the positive power supply connection via a 1A rated fuse or circuit breaker.
  - The black wire should be connected to the negative power supply connection.

### Installation step 3

Apply power and verify the unit is operating:

- Apply power to the antenna splitter, AIS Transponder and VHF radio telephone.
- Verify that the green power LED on the antenna splitter is illuminated.
- Transmit using the VHF radio telephone and verify that the yellow LED on the antenna splitter marked 'VHF' is illuminated during the transmission.

Wait for the AIS Transponder to transmit its first position report. This is indicated by the green power LED on the AIS Transponder illuminating. During AIS Transponder transmissions the yellow 'AIS' LED on the antenna splitter will flash briefly. Class B AIS transmissions occur once every 3 minutes if your vessel is stationary.

### OPERATION

Operation of the antenna splitter is automatic and requires no user intervention.

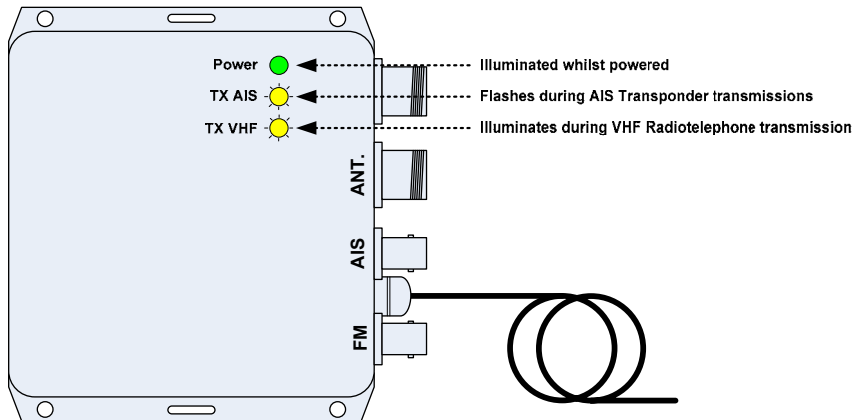

- During operation the antenna splitter will share signals received at your VHF antenna with both the VHF Radiotelephone and the AIS Transponder.
- When either connected device transmits, the antenna splitter will automatically route the transmission to the antenna.
- VHF Radiotelephone transmissions (including DSC transmissions) are given priority over AIS transmissions.

** It is not possible for both connected devices to transmit simultaneously using a single VHF antenna. Whilst you are talking on your VHF Radiotelephone no AIS position reports will be transmitted.**

### TROUBLESHOOTING

Problem	Solutions
Power LED not illuminated	<ul style="list-style-type: none"><li>• Check power supply connections and fuse or circuit breaker.</li><li>• Check polarity of power supply connections.</li><li>• Check power supply voltage.</li></ul>
'VHF' LED does not illuminate when VHF Radiotelephone is transmitting.	Check the antenna output of the VHF radiotelephone is connected to the antenna splitter input labelled 'VHF'.
'AIS' LED does not illuminate when AIS Transponder is transmitting.	Check the antenna output of the AIS transponder is connected to the antenna splitter input labelled 'AIS'.
Clicks or pops are heard from a connected FM broadcast receiver.	This is normal and may occur during VHF or AIS transmission.
VHF or AIS reception range is reduced.	A slight reduction in receiver range is normal and due to the insertion loss of the antenna splitter.

### **DECLARATION OF CONFORMITY**

#### **DECLARATION OF CONFORMITY with the R&TTE Directive 1999/5/EC**

We, True Heading AB of Åminnevägen 19, 114 18 Stockholm, Sweden declare under our sole responsibility that the product CLASS B VHF ANTENNA SPLITTER, being an AIS Transponder Antenna Splitter, to which this declaration relates, is in conformity with the relevant sections of the following standards and/or other normative documents.

#### **For Article 3.1(a) [Health & Safety]:**

Health:

EN 50384: 2002 for occupational exposure to electromagnetic fields

EN 50385: 2002 for general public exposure to electromagnetic fields

EN 50383: 2002 which is referenced by EN 50384: 2002 and EN 50385: 2002

Safety:

EN 60950-1: 2001, Clauses 1.5 – 1.8, 2.2, 2.5, 2.9, 3, 3.5, 4, 4.5 – 4.7 & 5

IEC 60945: 2002-08, Clauses 7, 8.2, 8.3, 8.7, 8.8, 8.12 & 11.2

#### **For Article 3.1(b) [EMC]:**

EN 301 843-1 v1.2.1 (2004-06)

IEC 60945: 2002-08, Clauses 9.2, 9.3, 10.3, 10.4, 10.5 & 10.9

#### **For Article 3.2 [Spectrum usage]:**

IEC 62287-1: 2006-03 Clause 11, for the AIS transmitter and receivers

IEC 62287-1: 2006-03 Annex C, Clause C4, for the DSC receiver

IEC 61108-1: 2003-07 Clauses 4.3.7 & 4.3.8, for the GPS receiver

#### **For Article 3.3(e) [Access to emergency services]:**

IEC 62287-1: 2006-03 Clause 9, for operation in intended environment

IEC 62287-1: 2006-03 Clauses 10, 12, 13 for operational requirements

We hereby declare that all essential radio test suites have been carried out and that the above named product is in conformity to all the essential requirements of Directive 1999/5/EC. The conformity assessment procedure referred to in Article 10 and detailed in Annex [III] and [IV] of Directive 1999/5/EC has been followed with the involvement of the following Notified Body:

## Class B VHF Antenna splitter Manual

---

BABT, Balfour House, Churchfield Road, Walton-on-Thames, Surrey, KT12 2TD, UK.  
Identification mark: 0168

The technical documentation relevant to the above equipment will be held at True Heading AB.

The product is intended for sale in the following member states:

Intended Country of Use:			
<input type="checkbox"/> GB	<input type="checkbox"/> FR	<input type="checkbox"/> ES	<input type="checkbox"/> SE
<input type="checkbox"/> AT	<input type="checkbox"/> NL	<input type="checkbox"/> PT	<input type="checkbox"/> DK
<input type="checkbox"/> NO	<input type="checkbox"/> BE	<input type="checkbox"/> IT	<input type="checkbox"/> FI
<input type="checkbox"/> IE	<input type="checkbox"/> LU	<input type="checkbox"/> GR	<input type="checkbox"/> CH

Anders Bergström

**Manager, True Heading AB**

Signed: 

Date: 30<sup>th</sup> July 2008

**FAQ**

TBP

**NOTES**

## DRAWINGS

