

Installation guide for True Heading VHF SPLITTER

This quick installation guide describes the most basic information you need to install your VHF SPLITTER receiver. Please visit our webpage (www.trueheading.se) for updates on manuals etc.

i. Introduction

The VHF SPLITTER from True Heading is an active antenna splitter that blocks the reception on the connected AIS receiver during transmission from the also connected VHF transceiver. The VHF SPLITTER can handle a maximum output power from the transmitting unit of 25 W in the frequency band 155-163 MHz. **The VHF SPLITTER needs at all time to be connected to 12 V DC to have full operational capacity and not to damage any of the connected equipment. The AIS receiver also at all time needs to be connected to the VHF SPLITTER during operation to secure full functionality and not to damage any of the connected equipment.**

Physical	L x W x H: 93 x 39 x 33 (mm) Weight : 50g
Connectors:	VHF = UHF male VHF antenna = UHF female AIS receiver = BNC male
Loss :	3dB
	VHF max output power: 25 W

ii. Checking your material

Check that you have received all the equipment with your VHF SPLITTER. It shall be the splitter with 3 cables as shown below on the picture. Check that the delivered equipment has not been damaged during delivery. If the equipment has been damaged, please contact your reseller or our support.

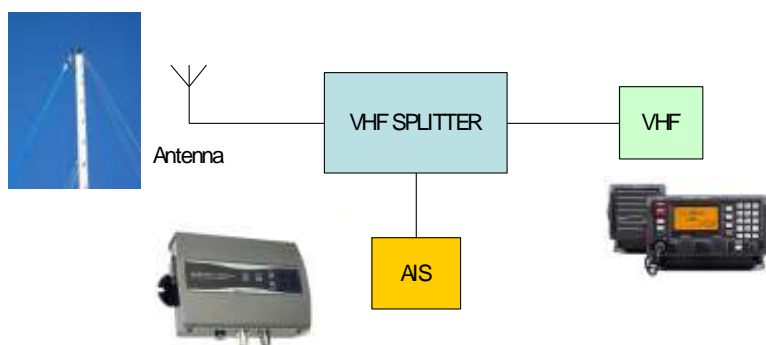

iii. Mounting

The VHF SPLITTER is made to be installed in a protected environment (in door) and shall therefore be placed where its well protected from humidity and water. The VHF SPLITTER can either hang loose connected to the VHF radio or mounted with the included mounting brackets. Make sure that the VHF SPLITTER can not be physically damaged from if you decide not to mount it fixed.

iv. Installing your receiver

The installation of your VHF SPLITTERN is fairly simple. Start with disconnecting the antenna on your VHF radio. It shall be of the type UHF male and can then be connected to the VHF SPLITTERN connector that is clearly marked with an arrow stating "ANT". If the antenna connector is of a different type you will need change it or convert it by using an adapter. Continue by taking the cable on the VHF SPLITTERN that is marked "VHF" and connected that to your VHF radio, where your VHF antenna cable used to be. If the radio should have another type of connector you need to change the connector on the VHF SPLITTERN or convert the connector with an adapter. Finally take the cable marked with an arrow and the text "AIS" and connect it to your AIS RX YACHT or SR 162 that has the connector of the type BNC male and can only be connected to the corresponding connector on the AIS receiver. Make sure that all connectors are properly tighten and in their fixed end positions. Connect then the VHF SPLITTERN to 12 V DC. Preferably this should be done to the same power source that feeds the VHF with power. Also check during installation that proper grounding is obtained. Having grounding problems might damage the equipment (mainly the AIS Receiver).

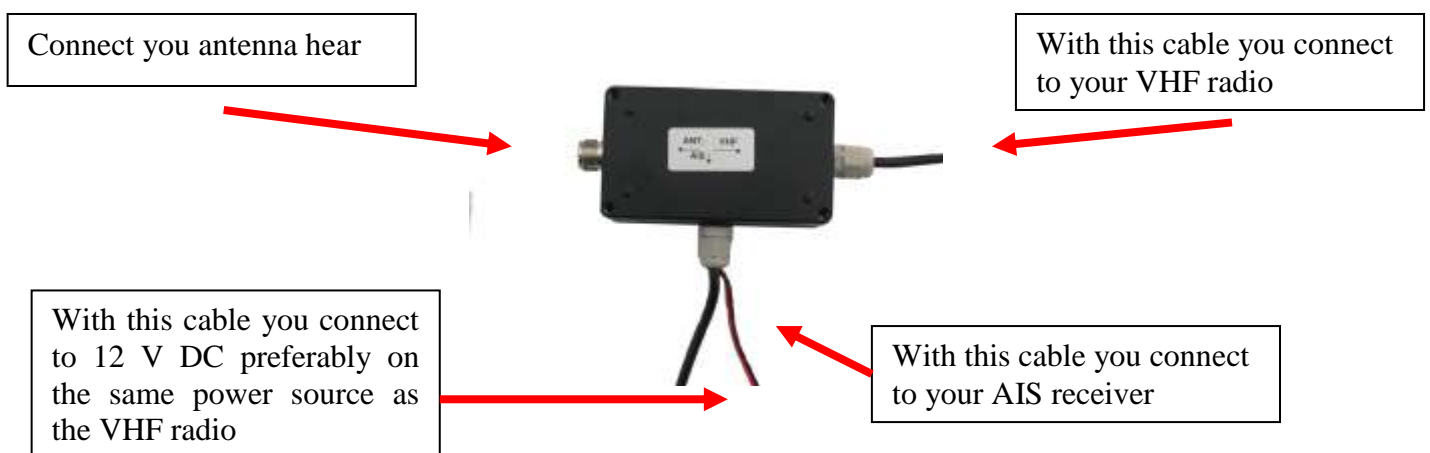

vi. Connect to power

Connect the VHF SPLITTERN to 12 V DC using preferably the same power connection as the VHF radio. Make sure that the VHF SPLITTERN like the radio is secured using a proper fuse. Also check that no grounding problems exists since this mainly might damage the AIS receiver. The VHF SPLITTERN comes with a power cable that needs to be connected as follows:

Red is plus

Black is minus

VHF SPLITTERN can be connected and work from 9-16 V DC and consumes less then 0,1 W.